

Funkenerosion



Your advantage:

- ✓ Technology advice for special requirements
- ✓ Permanent quality control by eroding tests
- ✓ Not only dealer but also machine manufacturer with own wage labour!
- ✓ Special sizes \varnothing 0,08 - 6,0 mm
Available ex stock. u.ü.V

Spare & wear parts catalouge Start hole EDM drilling machine S-26

Accessories, wear- and spare parts directly from machine manufacturer.

Heun Funkenerosion GmbH
Lange Hecke 4
63796 Kahl/Main

Tel.: +49 (0)6188/9105-10
Fax: +49 (0)6188/9105-40

info@heun-gmbh.de
www.heun-gmbh.de

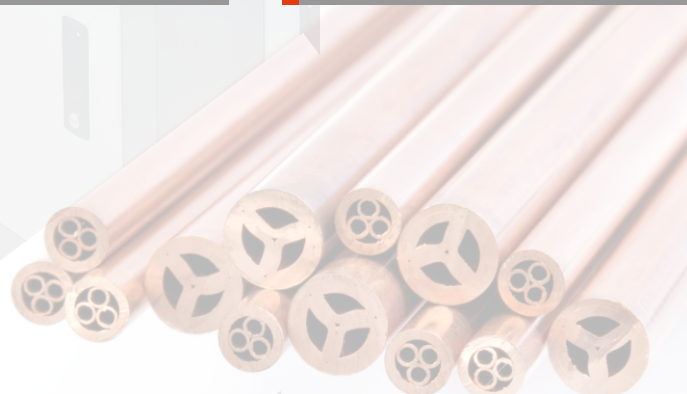

Contents

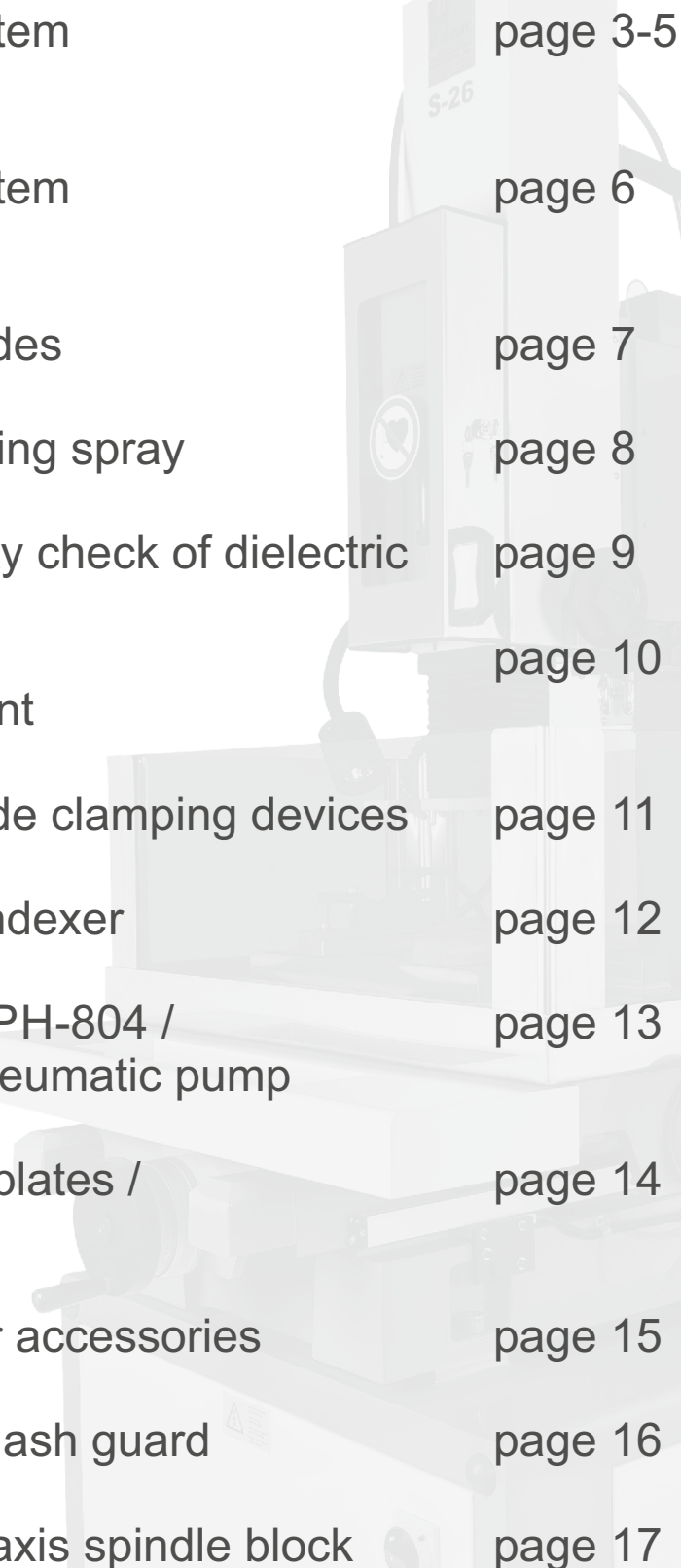
- 
1. electrode clamping system for ER16 spindle page 3-5
 2. electrode clamping system for chuck adapter page 6
 3. electrode / ceramic guides page 7
 4. cleaning agents / cleaning spray page 8
 5. drilling additives / quality check of dielectric page 9
 6. Tank- and filter unit/
cooling unit filter element page 10
 7. chuck adapter / electrode clamping devices page 11
 8. clamping nut / option indexer page 12
 9. high-pressure pump MPH-804 /
high-pressure pump pneumatic pump page 13
 10. pump / guide holding plates /
clamping devices page 14
 11. flushing tubes / further accessories page 15
 12. operation manual / splash guard page 16
 13. central lubrication / c-axis spindle block page 17

1

2

3

4

5

6

7

8

9

10

11

12

13



electrode clamping system for ER16 spindle for collet chuck

	article no.	name	pc./set
1.	630 300 010	c-axis spindle block without motor (ER 16)	1 pc.
2.		ER 16 rubber packing	
	340 610 108	0,5 mm - 1,0 mm	1 pc.
	340 610 102	1,0 mm - 2,0 mm	1 pc.
	340 610 103	2,0 mm - 3,0 mm	1 pc.
	340 610 104	3,0 mm - 4,0 mm	1 pc.
	340 610 105	4,0 mm - 5,0 mm	1 pc.
	340 610 106	5,0 mm - 7,0 mm	1 pc.
3.	340 610 110	brass disc ER	1 pc.*
4.		collet chuck ER16	
	110 400 015	collet chuck Ø 0,5 - 1,0 mm	1 pc.
	110 400 020	collet chuck Ø 1,0 - 2,0 mm	1 pc.
	110 400 030	collet chuck Ø 2,0 - 3,0 mm	1 pc.
	110 400 040	collet chuck Ø 3,0 - 4,0 mm	1 pc.
	110 400 050	collet chuck Ø 4,0 - 5,0 mm	1 pc.
	110 400 100	collet chuck Ø 5,0 - 6,0 mm	1 pc.
	632 100 200	special collet chuck ER16 up to Ø 3,0 mm	1 pc.
5.	315 550 090	cap nut ER 16	1 pc.

Other diam. on inquiry!



electrode clamping system for ER16 spindle for drill chuck

	article no.	name	pc./set
1.		ER 16 rubber packing	
	340 610 101	up to 0,4 mm	1 pc.
	340 610 108	up to 1,0 mm	1 pc.
	340 610 102	up to 2,0 mm	1 pc.
	340 610 103	up to 3,0 mm	1 pc.
	340 610 104	up to 4,0 mm	1 pc.
	340 610 105	up to 5,0 mm	1 pc.
	340 610 106	up to 7,0 mm	1 pc.
2.	315 550 125	ER precision-chuck (Ø 0,2 - 3,0 mm) incl. cone and nut for für collet chuck adapter	1 pc.



electrode clamping system

special collet ER16 Spindel for drill chuck

	article no.	name	pc./set
1.	632 100 200	special collet ER16	1 pc.
2.	632 100 300	clamping nut for special collet	1 pc.
3.		rubber packing drill chuck seat	
	100 800 500	type A up to 0,5 mm	1 set (4 pcs.)
	100 801 300	type B up to 1,3 mm	1 set (4 pcs.)
	100 802 300	type C up to 2,3 mm	1 set (4 pcs.)
	100 803 200	type D up to 3,2 mm	1 set (4 pcs.)
	100 804 000	type E up to 4,0 mm	1 set (4 pcs.)
4.	632 100 100	adapter cone of drill chuck	1 pc.
5.	101 000 200	Albrecht precision quick drill chuck 0,0-3,0 mm	1 pc.
	alternative		
6.	101 000 100	geared rim drill chuck 0,3-3,0 mm	1 pc.

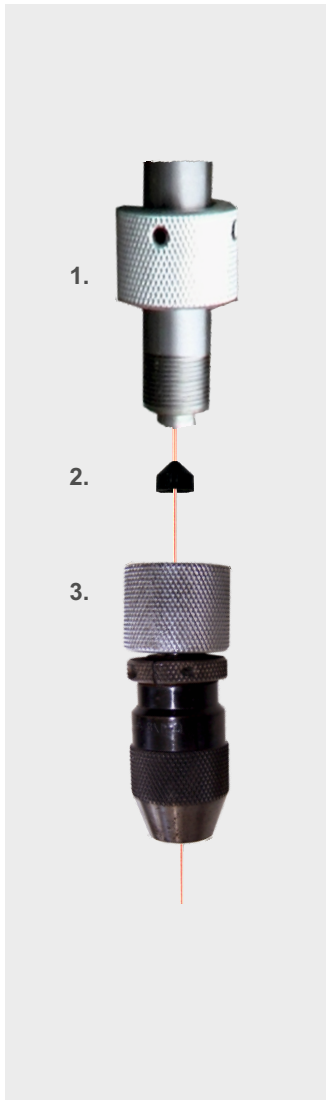

electrode clamping system for drill chuck seat

	article no.	name	pc./set
1.	630 300 020	c-achis spindle block (without motor)	1 pc.
2.		rubber packing drill chuck seat	
	100 800 500	type A up to 0,5 mm	1 set (4 pcs.)
	100 801 300	type B up to 1,3 mm	1 set (4 pcs.)
	100 802 300	type C up to 2,3 mm	1 set (4 pcs.)
	100 803 200	type D up to 3,2 mm	1 set (4 pcs.)
	100 804 000	type E up to 4,0 mm	1 set (4 pcs.)
3.	318 591 203	precision-holder Ø 0,2 - 3,0 mm (complete)	1 pc.

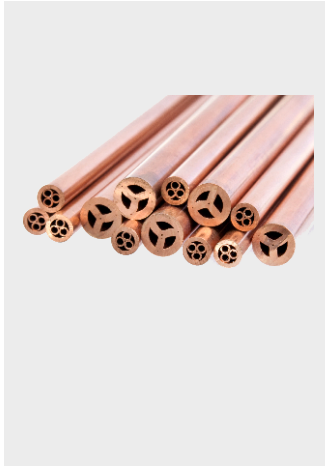

electrodes

quantity discount: 100 pcs. **6 %** 500 pcs. **8 %** 1.000 pcs. **10 %**

article no.	name	pc./set
	brass & copper electrodes single 300/400 mm lenght Ø 0,3 - 3,0 mm	1 set (20 pcs.)
	brass & copper electrodes coreless 300/400 mm lenght Ø 0,5 - 3,0 mm	1 set (20 pcs.)



ceramic guides

Special sizes we can customize according to their requirements.

article no.	name	pc./set
1. 100 4xx xxx	Ø 0,1 - 3,0 mm swiss precision guide (art.no.: xx replace by Ø)	1 pc.
2. 110 30x xxx	guide extension, diff. length, special length on inquiry	1 pc.
3. 101 400 800	miniature ceramic guide Ø 0,08 mm	1 pc.
4. 101 400 900	miniature ceramic guide Ø 0,09 mm	1 pc.
5. 101 4xx xxx	miniature ceramic guide from Ø 0,1 mm - 3,0 mm	1 pc.
6. 340 800 223	holder for miniature-precision- ceramic guide AØ 2,5 mm	1 pc.



cleaning agents for machine

suitable for every Heun machine

	article no.	name	pc./set
1.	190 200 100	Wirasol special cleaner 10 litre can	1 pc.
1.	190 200 108	Wirasol special cleaner 5 litre can	1 pc.
2.	190 200 500	EDM clean 10 litre can	1 pc.*
2.	190 200 508	EDM clean 5 litre can	1 pc.*



cleaning spray for machine

suitable for every Heun machine

	article no.	name	pc./set
1.	190 400 000	CRC-3-36 5 litre can	1 pc.*
2.	190 430 000	CRC-3-36 sprayer 250 ml / 300 ml	1 pc.
3.	190 600 100	hand sprayer 400 ml	1 pc.

* These articles are essential to be kept on stock.

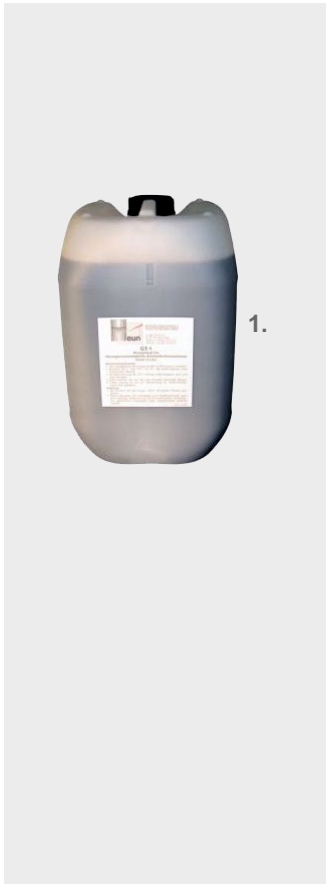

drilling additives

for steel- und carbide metal working in water basin

	article no.	name	pc./set	price á set
1.	100 701 100	EX-01 Konzentrat 10 l can (steel machining)	1 pc.	274,90 €



quality check of dielectric

	article no.	name	pc./set
1.	251 000 100	conductance measuring device	1 pc.*
2.	251 000 200	refractometer	1 pc.



tank- and filter unit / cooling unit

	article no.	name	pc./set
1.	250 200 915	cooling unit 2,6 KW	1 pc.
2.	111 600 100	stainless steel submerged pump	1 pc.
3.	340 200 150	heat exchanger	1 pc.
4.	631 000 101	key for filter housing	1 pc.
5.	631 000 100	filter housing for water filter	1 pc.
6.	631 000 110	o-ring for filter housing	1 pc.
7.	311 830 150	external tank- and filter unit TFA-200 (without filling - EX-01 see page 8)	1 pc.
8.	630 100 115	slush pump L-2500	1 pc.



filter elements

	article no.	name	pc./set
1.	240 000 S26	filter for S-26 (white)	1 pc.*
2.	240 0BE P05	filter cartridge BEP 5 for TFA-150	1 set* (6 pcs.)
3.	311 830 130	web filter for TFA 200/290 Litre	1 set (2 pcs.)

* These articles are essential to be kept on stock.

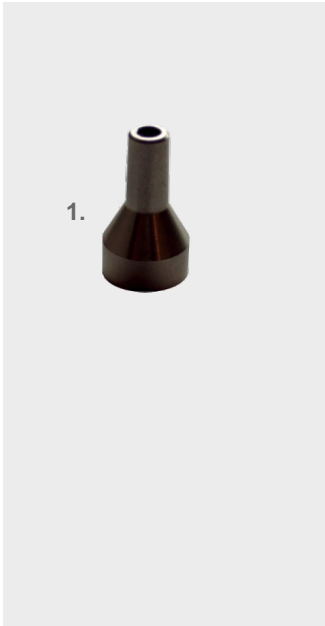

chuck adaptor

	article no.	name	pc./set
1.	630 800 200	chuck adaptor	1 pc.

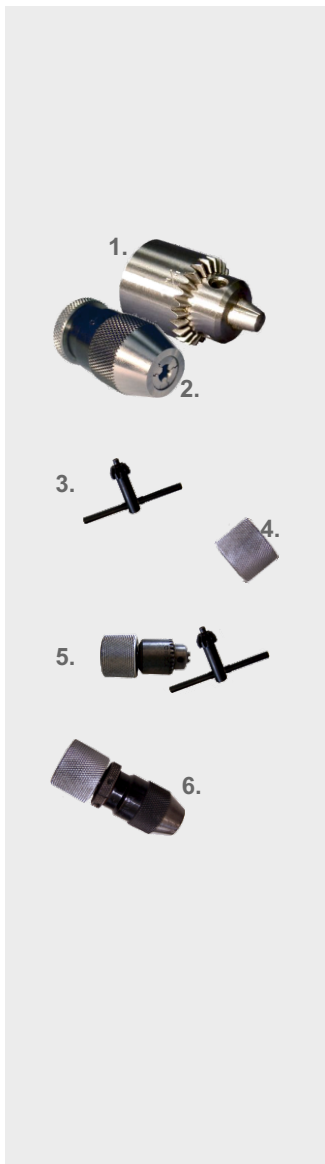

electrode clamping devices

	article no.	name	pc./set
1.	101 000 100	geared rim drill chuck 0,3-3,0 mm	1 pc.
2.	101 000 200	Albrecht precision quick drill chuck 0,0-3,0 mm	1 pc.
3.	101 000 500	key for drilling chuck with gear rim	1 pc.
4.	630 800 300	fixing nut for drill chuck	1 pc.
5.	630 800 500	geared rim drill chuck set 0,3-3,0 mm (complete) inkl. cone + nut + key	1 pc.
6.	630 800 400	Albrecht precision quick drill chuck - set 0,0-3,0 mm (complete) inkl. cone + nut	1 pc.



clamping nut



1.-2.

	article no.	name	pc./set
1.	632 100 300	clamping nut for special collet ER 16	1 pc.
2.	110 400 300	clamping nut for ER 16	1 pc.

option indexer



1.

	article no.	name	pc./set
1.	110 200 320	indexer URT 2002 with automatic control	1 pc.



high-pressure pump MPH-804



	article no.	name	pc./set
1.	530 600 000	sealing kit for high-pressure pump MPH-804	1 set*
2.	530 500 045	valve für pump MPH-804	1 pc.
3.	530 600 100	Oil for HD-pump MPH-804	1 litre*
4.	530 500 055	unloader unit MPH-804	1 pc.
5.	530 500 000	high-pressure pump MPH-804	1 pc.
6.	530 500 060	pump head brass incl. sealings / valves	1 pc.
7.	101 850 000	high-pressure hose, length 1,00 m for ceramic piston pump	1 pc.*
8.	101 860 000	high-pressure hose, length 1,70 m for ceramik piston pump	1 pc.*

high-pressure pump pneumatic pump

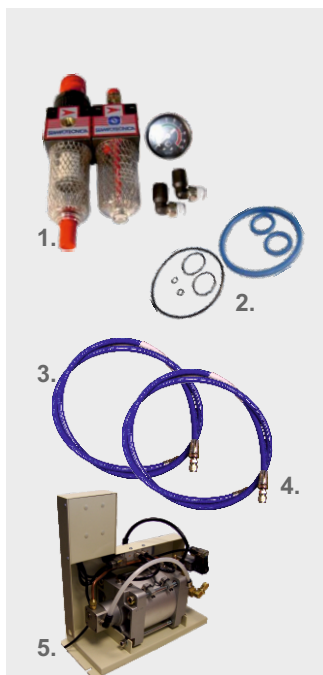

	article no.	name	pc./set
1.	315 530 106	pressure regulator + Oiler maintenance unit	1 pc.
2.	630 100 300	pneumatic pump seal kit	1 set*
3.	101 830 000	high-pressure hose, length 1,00 m for pneumatic pump	1 pc.*
4.	101 840 000	high-pressure hose, length 1,40 m for pneumatic pump	1 pc.*
5.	315 580 101	pneumatic pump S-26 complete	1 pc.



start hole EDM drilling machine S-26



Spülpumpe

	article no.	name	pc./set
1.	630 100 110	flushing pump CK301	1 pc.



guide holding plate

	article no.	name	pc./set
1.	630 301 600	guide holding plate Ø 6 mm standard	1 pc.
2.	630 301 609	guide holding plate Ø 9 mm	1 pc.
3.	630 301 612	guide holding plate Ø 12 mm (for ceramic guide 8 mm & single guide holder)	1 pc.
4.	340 800 223	holder for miniature-precision-ceramic guide AØ 2,5 mm	1 pc.
5.	630 301 650	brass socket, various reductions to Ø 6,00 mm	1 pc.



clamping devices

	article no.	name	pc./set
1.	420 300 600	clamping jaws stainless steel L=95 mm	1 set (2 pcs.)
2.	420 300 700	clamping screws stainless steel	1 set (8 pcs.)
3.		clamping devices of leading manufacturers 3R/Hirschmann/Erowa	



flushing tube

	article no.	name	pc./set
1.	630 200 100	flushing tube with magnet base	1 pc.
2.	630 200 200	flushing tube mounted on drilling head	1 pc.



further accessories

	article no.	name	pc./set
1.	240 0VL S26	air filter mat 425 mm x 260 mm	1 pc.
2.	240 0VL 333	air filter mat rough withe 170 gr. 10-12 mm	á m ²
3.	101 100 000	rubber slider	1 pc.
4.	630 300 700	fuse set	1 set. (9 pcs.)
5.	630 310 600	halogen lamp without transformator	1 pc.
6.	630 310 620	halogen lamp with transformator	1 pc.
7.	250 300 250	halogen bulb 20 W / 12 V replacement	1 pc.
8.	630 300 550	bellow with steel frame	1 pc.



operating instruction

	article no.	name	pc./set
1.	325 000 350	operating instruction (digital)	1 pc.
2.	325 000 300	operating instruction (hard copy)	1 pc.

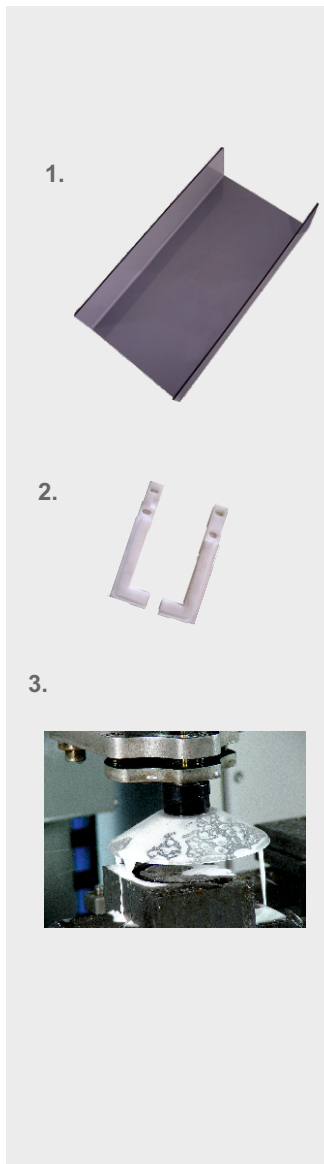

splash guard

	article no.	name	pc./set
1.	630 310 000	splash guard U-profile	1 pc.
2.	630 310 050	splash guard fixture for U-profile	1 set (2 pcs.)
3.	315 580 175	splash guard for guide	1 set (5 pcs.)

Other splash guard forms on inquiry.



central lubrication



	article no.	name	pc./set
1.	630 301 300	central lubrication	1 pc.
2.	630 301 400	oil for central lubrication	1 litre*

c-axis spindle block

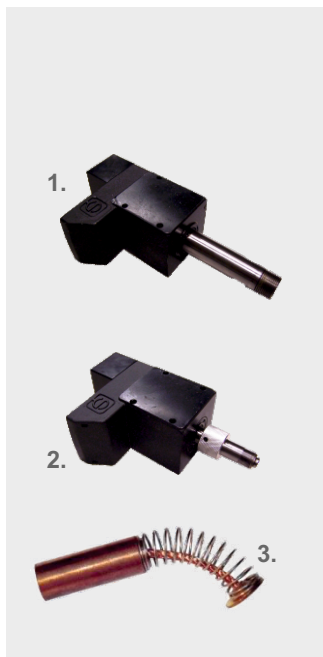

	article no.	name	pc./set
1.	630 300 010	c-axis spindle block without motor (ER 16)	1 pc.
2.	630 300 020	c-axis spindle block without motor for chuck	1 pc.
3.	102 600 000	carbon brush	1 set * (2 pcs.)

Terms of payment are subject to agreement.

Technical details and prices are subject to change!
Pictures and data are non-committal.

For technical questions please contact us via
e-mail techniker@heun-gmbh.de

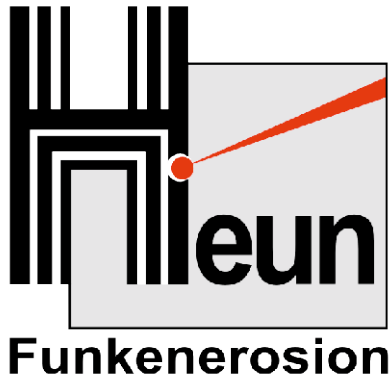

HEUN Funkenerosion GmbH
Lange Hecke 4
63796 Kahl / Main
GERMANY

Tel.: +49 6188 9105-10
Fax.: +49 6188 9105-40

info@heun-gmbh.de
www.heun-gmbh.de

service and spare parts

- phone-service
- online-service
- remote diagnosis
- 24-hour-service

Hotline +49 6188 9105-25
techniker@heun-gmbh.de

Date: 06/2023

Technical details and prices are subject to change! Pictures and data are non-committal.

