

Serie

TR-100

Broken tap remover



view example TR-100

As a specialist in the field of **EDM drilling**, Heun offers the **all-round package** from development and perfecting, as well as manufacture and delivery, up to service.

The advantages at a glance:

QUICK * LOW COST * HIGH PERFORMANCE

- light, small, portable, compact design
- high speed, high efficiency
- low cost
- simple operation
- using any brass or copper bar as electrode
- machining easily even on a large work piece
- auto feed
- easily remove broken tap
- using ordinary tap water as machining dielectric liquid
- remove taps easily without damage on the threads
- more applications: startholes for wire cut EDM, cutting tungsten carbide or any hardened steel



Heun Funkenerosion GmbH * Lange Hecke 4
63796 Kahl am Main * Germany

phone: +49 6188/910-510 * fax: +49 6188/910-540
www.heun-gmbh.de * info@heun-gmbh.de

machining applications

1 small work piece

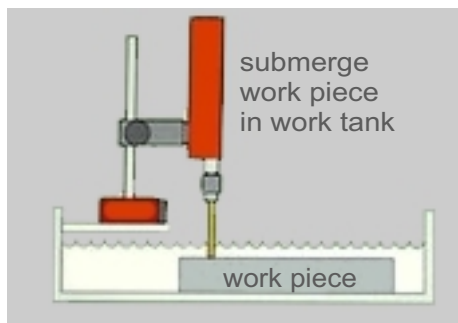

2 large work piece

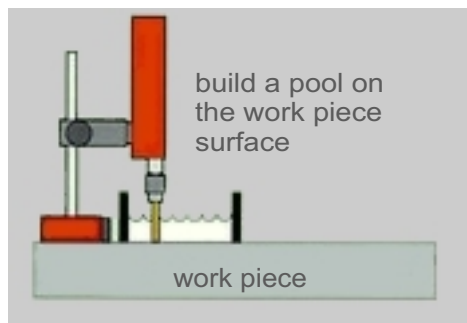

3 non-vertical machining

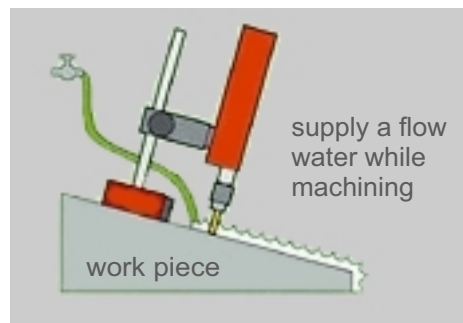

functions

- auto feed
- depth setting
- selectable arcing timer
- work head swivel
- auto retract
- alarm messages: depth arrival, arcing, overheating

Technical details generator

weight:	kg	17
dimensions:	mm	290x345x285

Technical details workhead swivel

weight with magnetic stand:	kg	8
dimensions:	mm	53x70x375
electrode holder:	mm	Ø 6,5

dimensions

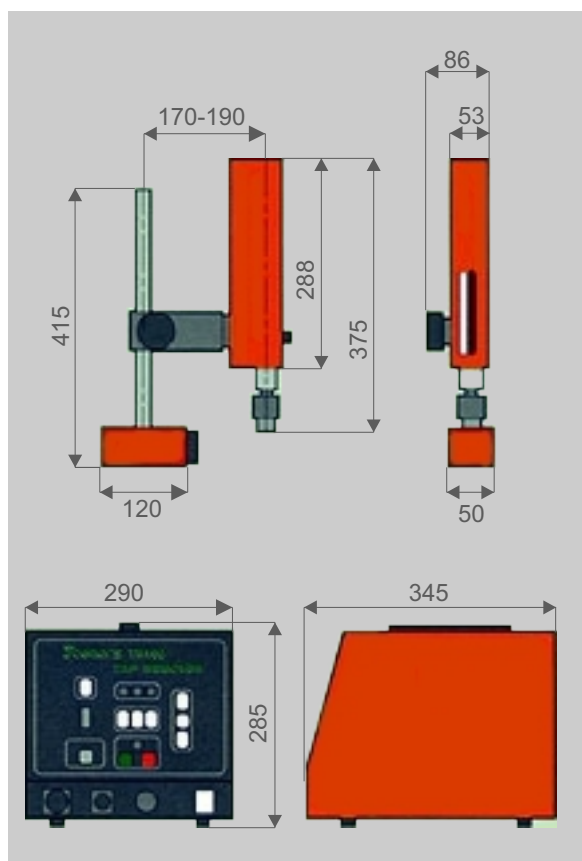

how to remove broken tap

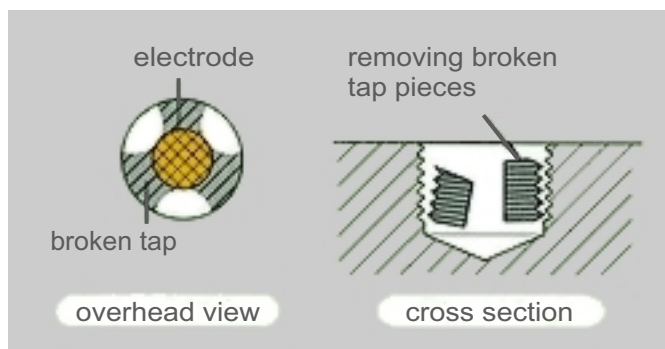

workhead swivel

